

# MMC instruction manual

<b>1</b>	<b>Introduction</b> .....	<b>1</b>
1.1	Overview.....	1
1.2	Introduction.....	1
1.2.1	Mother board.....	1
1.2.2	4-channels PID module.....	2
1.2.3	Output module.....	3
1.2.4	Extension board.....	4
1.2.5	AI board.....	4
1.2.6	GPIO board.....	5
1.3	Specification.....	6
<b>2</b>	<b>Wiring and Switch Setting</b> .....	<b>8</b>
2.1	Mother Board.....	8
2.2	Output Board.....	9
2.3	Extension Board.....	9
2.4	PID Module.....	9
<b>3</b>	<b>Communication</b> .....	<b>10</b>
3.1	Specification.....	10
3.2	Communication Setting.....	10
3.3	Communication wiring.....	11
3.4	MODBUS Communication Protocol.....	11
3.4.1	General.....	11
3.4.2	Composition of Command Message.....	11
3.4.3	Response Message of MMC.....	11
3.4.4	MODBUS Message RTU Framing.....	14
3.5	Function Code Description.....	16
3.5.1	Read Data Registers [Function Code: 03].....	16
3.5.2	Read Input Registers [Function Code: 04].....	16
3.5.3	Write Single Coil [Function Code: 05].....	16
3.5.4	Write Single Register [Function Code: 06].....	18
3.5.5	Write Single Register [Function Code: 10].....	18

<b>4</b>	<b>Parameters Description and Data Register Map .....</b>	<b>19</b>
<b>4.1</b>	<b>Parameters Description .....</b>	<b>19</b>
4.1.1	User .....	19
4.1.2	Level PID .....	21
4.1.3	Option.....	23
4.1.4	Control Output .....	27
4.1.5	Program .....	27
4.1.6	Calibration .....	30
<b>4.2</b>	<b>Alarm Section.....</b>	<b>31</b>
<b>4.3</b>	<b>Data Register Map.....</b>	<b>34</b>
4.3.1	Controller Registers .....	34
4.3.2	Alarm Registers .....	37
4.3.3	AI Registers.....	39
4.3.4	DO and Alarm status Registers .....	39
4.3.5	DI Registers.....	39
4.3.6	Other Registers (Reserved for Engineer Use Only) .....	39

# 1 Introduction

## 1.1 Overview

The **MMC** (Multi-channels Modular Controller) system consists of a **mother board**, **4-channels PID modules**, **output modules** and **extension boards**; the **AI (analog input) module board** and **GPIO (General Purpose Input/Output) board** are options and customized depending on the application. One **MMC** system can control up to 32 (max.) channels PID control loops with various output devices such as Relay contact, Pulsed Voltage, 4 ~ 20mA or 0 ~10Vdc etc. An overview of the **MMC** system is shown in Fig. 1.

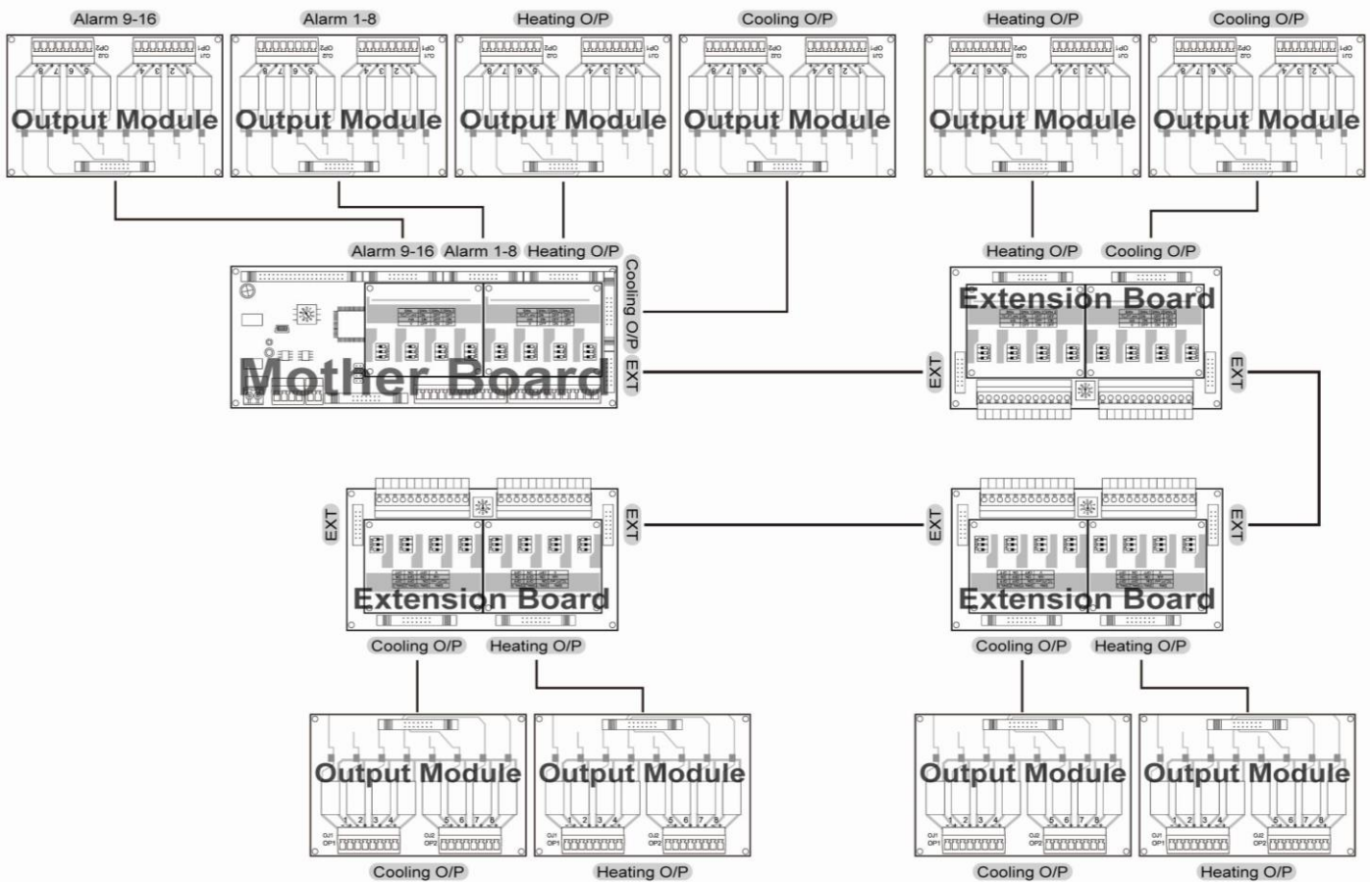

Figure 1. MMC system overview

### Feature

- Compact size – *Saving your assembly cost by reducing the space*
- Modular design – *Flexible combination to fulfill your control & measurement requirement*
- DIN rail mount – *Easy to installation*
- Plug connector – *Easy to wiring & maintenance*
- USB port – *Easy to configuration*

## 1.2 Introduction

### 1.2.1 Mother board

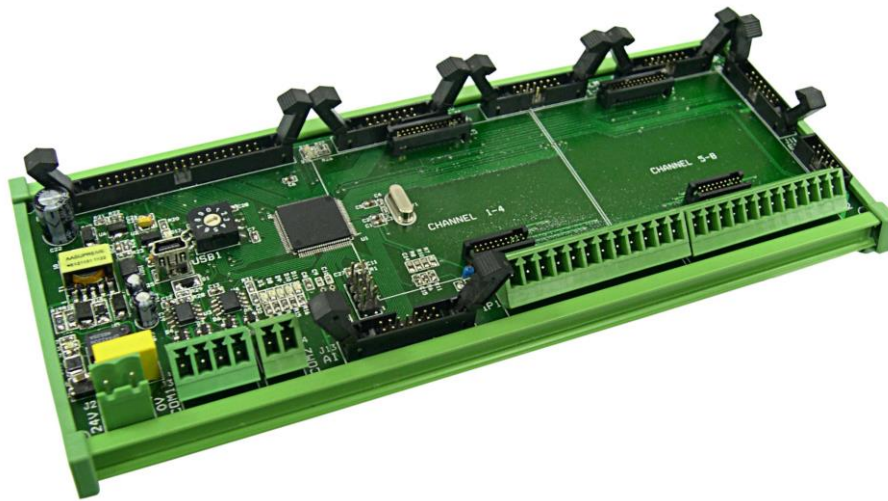

*Figure 2. Mother Board*

The mother board as shown in Figure 2 is the central part of a MMC system. It provides the major functions of MMC system which include two RS485 communication ports, up to 16 alarm output signal, 8 channels PID control loop with heating and cooling control output signal, one USB configuration port, 10 channels 12-bits A/D converter and 16 general- purpose I/Os. The powerful facilities have the features as below

- Two RS485 communication ports – One RS485 port can be set to interface with HMI (Human Machine Interface) or customize Display & keys board for local operation, the other can be set to interface with Supervisory or data acquisition system. Because of all the controlled parameters of linked 4-channels PID modules have been buffered into the memories of main CPU. It is possible to access all the controlled data with high communication speed up to 115.2K bps.
- Up to 16 alarm outputs – Each alarm can be freely assigned to any PID loops with various alarm modes.
- 8 channels PID control loop – 8 channels PID controller working independently provide high control performance without taking resource from main CPU.
- USB configuration port – This user-friendly USB port make it easy to configure the MMC setting.
- 12-bits A/D converter – The built-in 10 channels 12-bits A/D of the mother board are useful to convert any analog process variable to a digital measuring value. For example, a customize AI module with CT (Current Transformer) and rectifier circuit can be connected to the mother board to measure the load current of heating element.
- GPIO – The auxiliary general purpose I/O are useful to expend the digital input and/or output to perform logic control of controlled system.

### **1.2.2 4-channels PID module**

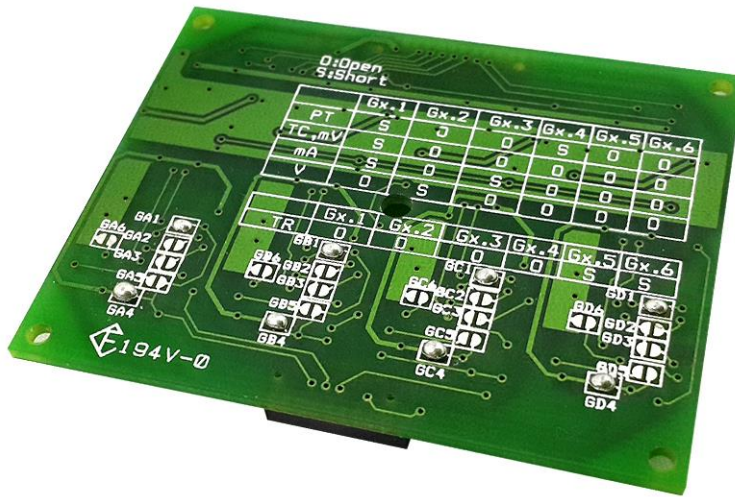

Figure 3. 4-channels PID module

The 4-channels PID module is a daughterboard to be mounted on the motherboard or extension board. It provides 4 channels independent PID control loop with various facilities.

- Universal input signal including various thermocouples, RTD, mV, mA and V.
- 24-bits A/D converter with 100ms sampling rate.
- Heating and cooling control output signals
- Ramp to set-point
- Soft start
- 8 segments (ramp & soak) programmable profile
- 4 independent level PID

### 1.2.3 Output module

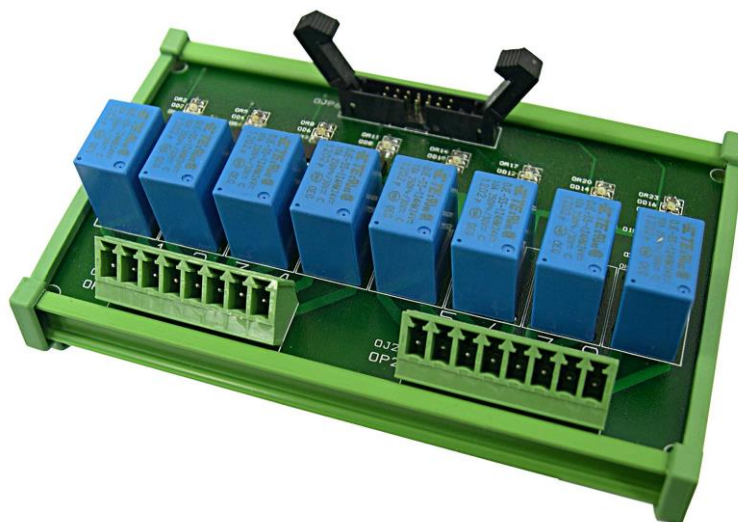

Figure 4. Output module - Relay

The output module takes control signals from the PID module or alarm signals from the motherboard to drive heating/cooling elements or alarm devices with various output devices. The output devices can be relay contact, Pulsed Voltage, 4 ~ 20mA or 0 ~ 10Vdc etc.

**1.2.4 Extension board**



*Figure 5. Extension board*

Maximum 3 extension boards can be connected to a MMC system. Each extension board can have 4 or 8 PID control loops by equipped with one or two 4-channels PID module. That is the PID control loop of MMC system can be extended up to 32 channels maximum.

**1.2.5 AI board**



*Figure 6. AI board for linear DC input*



*Figure 7. AI board for AC/DC current input*

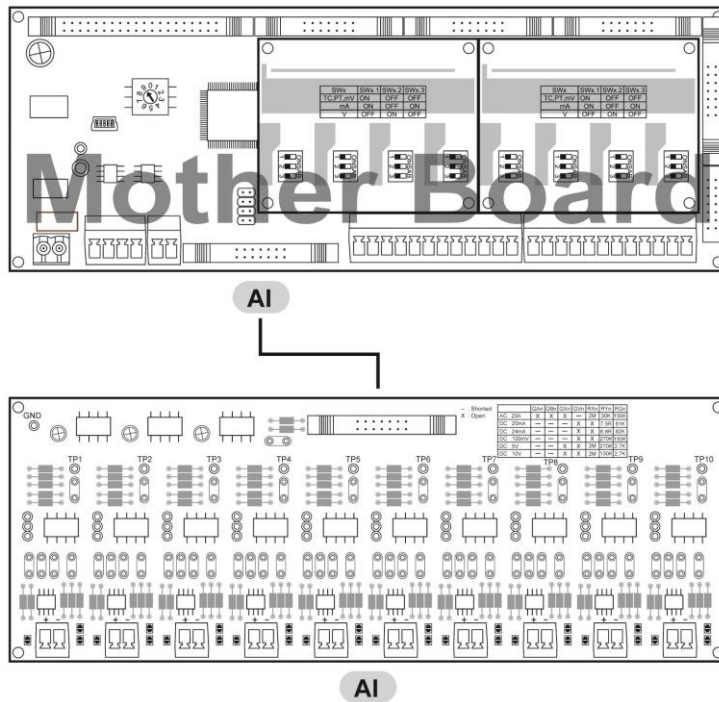

Figure 8. Connection of AI board

The AI board can be connected to the AI port to measure up to 10 channels analog signal with 12-bit resolution. There are two types of AI board. One is to measure DC signal such as 0~20/24mA, 0~100mV, 0~5V, 0~10V (part No. **MMC-AI-LN-xx**). The other can measure true RMS AC or DC current up to 30 Amp (part No. **MMC-AI-CT-xx**).

The measuring of DC input signal can be read from the AI registers and the measuring of AC/DC current can be read from the CT registers through the RS485 communication. ( please refer to section 4.3.3 AI registers )

### 1.2.6 GPIO board

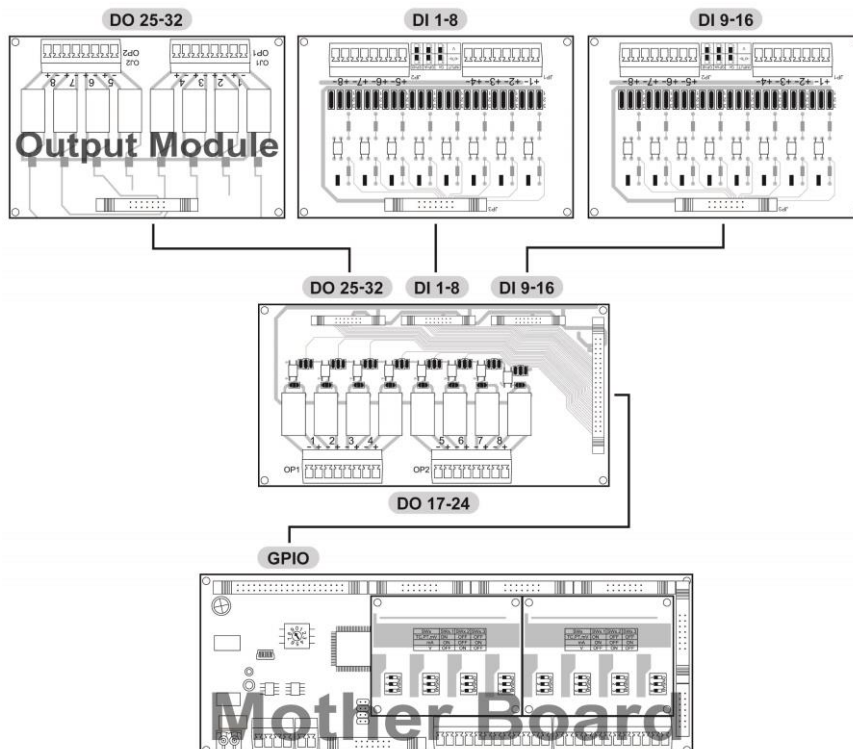

Figure 9. Connection of GPIO board



Figure 10. GPIO board

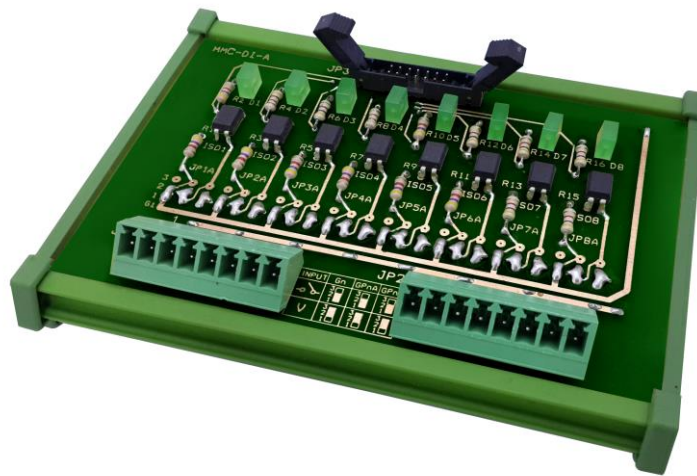

Figure 11. Digital Input board

The GPIO board equips with 16 DO (Digital Output) and 16 DI (Digital Input). The digital input status is read from the DI register and the digital output status can be read from or written to ALFG2 register. ( please refer to section 4.3.4 and 4.3.5 ) The 16 digital outputs can also be configured as alarm outputs (alarm 16 to alarm 32) separately.

### 1.3 Specification

Power supply: 24 Vdc  $\pm$ 20%

Power consumption:

Mother Board – 2VA with 2 PID modules

Output Module – 3.6VA (max.) each

Extension Board – 1VA with 2 PID modules each.

AI Board – 2VA (max.)

GPIO Board – 3.6VA (max.)

DI Board – 1.2VA (max.) each.



Sensor input:

Thermocouple

Type	Measuring/Setting Range	Accuracy
J	-50 ~ 1000 °C	±2°C
K	-50 ~ 1370 °C	±2°C
T	-270 ~ 400 °C	±2°C
E	-50 ~ 950 °C	±2°C
B	0 ~ 1800 °C	±2°C
R	-50 ~ 1750 °C	±2°C
S	-50 ~ 1750 °C	±2°C
N	-50 ~ 1300 °C	±2°C
C	-50 ~ 1800 °C	±2°C

RTD

Type	Measuring/Setting Range	Accuracy
PT100 (DIN)	-200 ~ 850 °C	±0.2°C
PT100 (JIS)	-200 ~ 600 °C	±0.2°C

Linear

Type	Scale/Setting Range	Accuracy
-10 ~ 10 V	-30000 ~ 30000 counts	±4mV
-50 ~ 50 mV	-30000 ~ 30000 counts	±20uV
4 ~ 20 mA	-30000 ~ 30000 counts	±10uA

Control mode: On/Off or P, PI, PD, PID

Sampling Rate of PID loop: 100ms each channel

Resolution of PID loop: 24-Bits A/D converter

No. of auxiliary GPIO: 32

Communication: RS485 interface with MODBUS RTU mode protocol, up to 115.2K bps

Memory: EEPROM (Non-volatile memory)

Ambient temperature: -10 ~ 55°C

Ambient humidity: RH 25 ~ 85%

Output Module:

Relay – SPST NO, 250Vac 3A resistive load

Pulsed Voltage – 24Vdc 24mA

4~20mA – 600Ω Max.

0~10Vdc – 500Ω Min.

Digital Input Module(DI):

Input – contact or 5 Vdc selectable

Isolation – 3750 V rms

Digital Output Module(DO):

Relay – SPST NO, 250Vac 3A resistive load

Analog Input Module (AI):

Resolution : 12-Bits A/D converter

Input signal : 0 ~ 20mA, 0 ~ 24mA, 0 ~ 100mV, 0 ~ 5V, 0 ~10V, 0 ~ 30 A rms

## 2 Wiring and Switch Setting

### 2.1 Mother Board

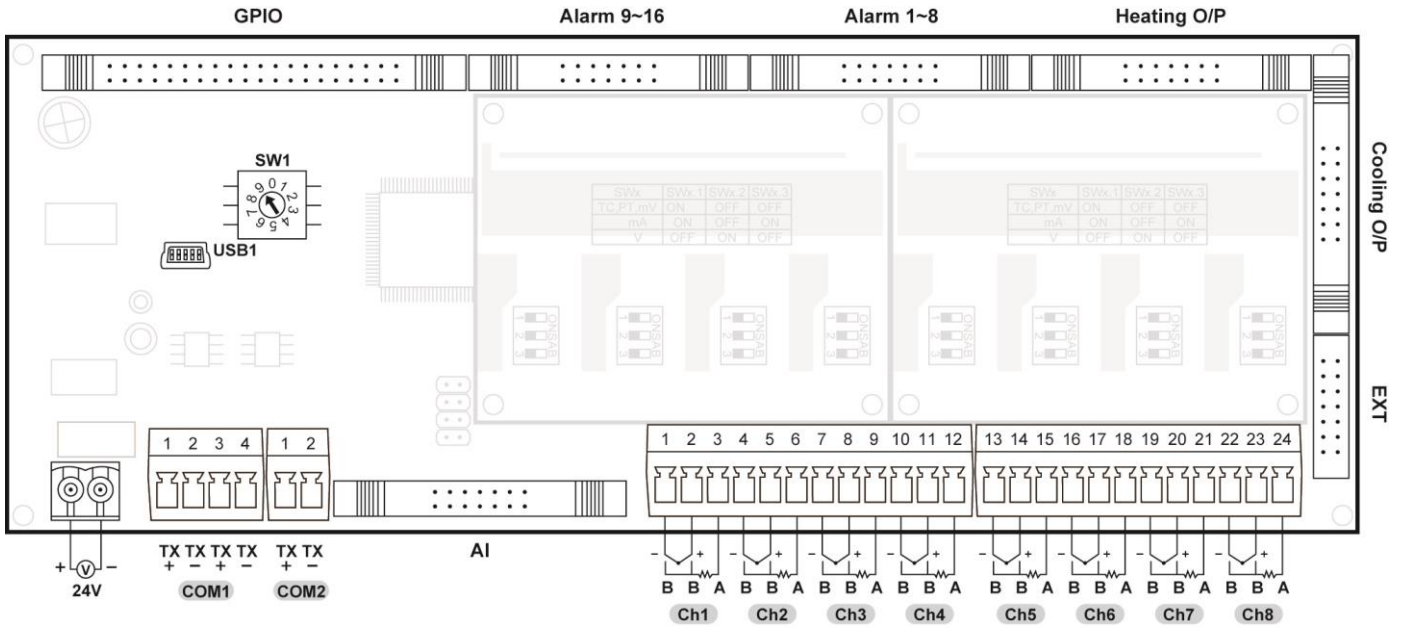

SW1: Set the ID of mother board in the range of 1 ~ 9. "0" is reserved for configuration purpose only. When set to "0", the MMC will be set to Baud Rate=9600 and ID=1. So no matter what the Baud Rate and ID of a MMC had been set , it can be communicated with 2 Stop bits,9600 Bps and ID=1.

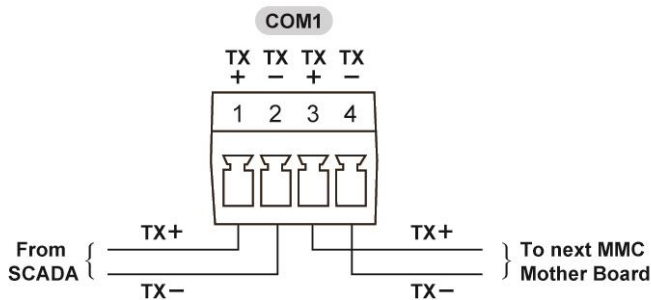

COM1: The COM1 connector has 4 pins. The pin 1 and 2 are connected to the master ( such as SCADA, supervisory control and data acquisition) ,the pin 3 and 4 are connected to the next mother board.

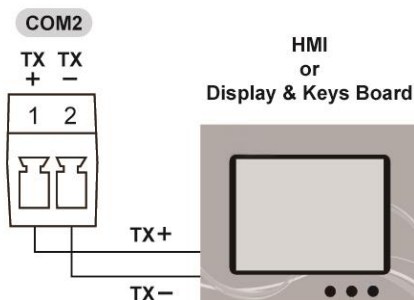

COM2: The COM2 connector can be connected to a HMI or Display & keys board for local operation.

## 2.2 Output Board

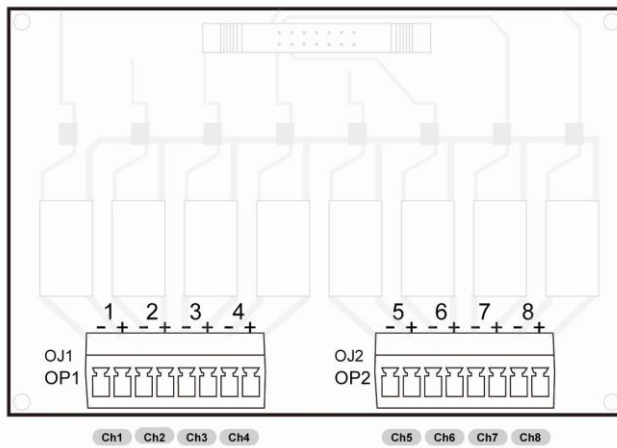

The output board can be equipped with various output device such as Relay, Voltage pulse to drive SSR or linear 4 ~ 20mA. It can also be a digital output (DO) connected to GPIO board.

## 2.3 Extension Board

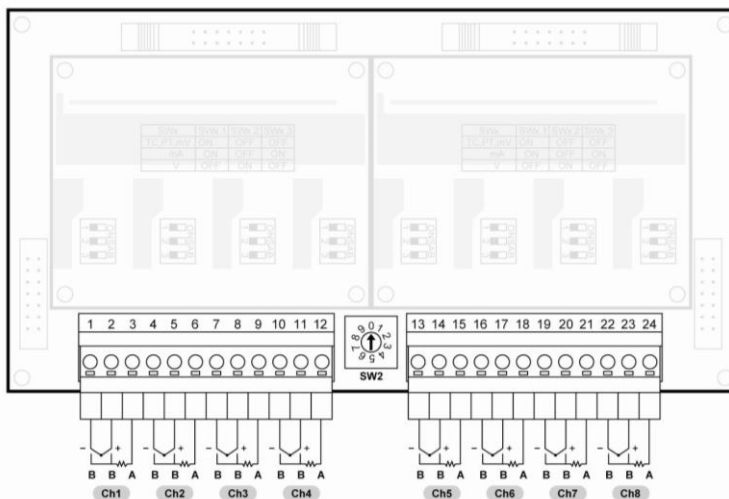

SW2: Set the SW2 in the range of 1 ~ 9. The SW2 of those extension boards connected to the same MMC system must be set to a value different to each other.

## 2.4 PID Module

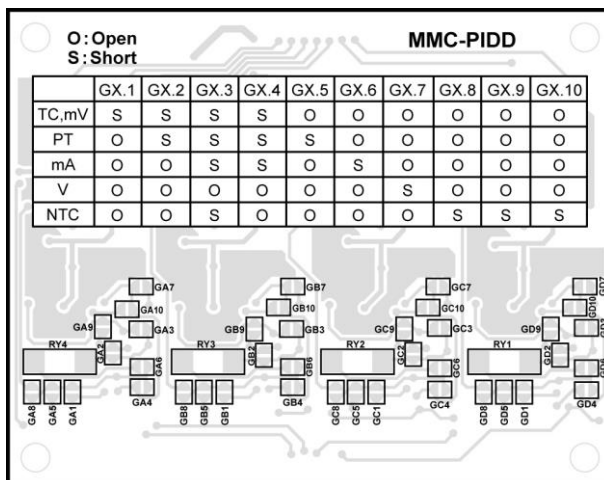

The gaps on the top of PCB are used to configure the hardware for various input signal for each channel. The setting is shown as the table on PID module.

### 3 Communication

#### 3.1 Specification

Item	Specification	
Electrical specification	Based on EIA RS-485	
Transmit system	2-wire, half-duplex	
Synchronizing system	Asynchronous mode	
Transmission distance	500m max	
Transmission speed	Up to 115.2K BPS	
Data format	Start bit	1 bit
	Data length bit	8 bits
	Parity bit	None
	Stop bit	1 or 2 bits selectable
Transmission code	HEX value (MODBUS RTU mode)	
Error detection	CRC-16 bits	

A typical MODBUS protocol character is shown below:

1	2	3	4	5	6	7	8	9	10	(11) *
1 Start bit	8 Data bits								1 or 2 Stop bit(s)	

#### 3.2 Communication Setting

In order that the master station and the **MMC system** can communicate correctly, following settings are required.

- ✓ All communication settings of the master station such as baud rate and data format must be same as those of **MMC systems**.
- ✓ Each **MMC system** connected on line is set to a unique address (ADDR) which is different from each others by setting the ID DIP switch (SW1) on the **MMC** mother board.

The baud rate and data format (1 or 2 Stop bit) of MMC can be set by the USB port. Since the baud rate and data format might has been set to any setting other than the default setting (BR=115.2K and data format = N82). It does really take times and is not realized to find out the current setting by trying any possibility.

**The ID DIP switch position "0" is reserved to force the communication setting to default setting temporarily in order that the user can change the communication setting (baud rate and data format) by the USB port along with the "Baud Rate Setting" software and the URC-1020 cable.**

The communication settings to be set are shown in the following table.

Parameter	Item	Default	Setting range	Remarks
Baud Rate	Transmission speed	9600	9600/19200 /38400/115200	Set the same communication condition to the master station and all slave station.
ID	Slave address	1	1 to 9 (Note 1)	Set a different value to each with the SW1 on the MMC mother board.
Stop Bit	Data Format	2	1 or 2	

Note 1: “0” is reserved for configuration purpose only. When set to “0”, the MMC will be with Baud Rate=9600 and ID=1 temporarily. So no matter what the Baud Rate and ID of a MMC had been set , it can be communicated with 2 Stop bits,9600 Bps and ID=1.

### 3.3 Communication wiring

- ✓ Use twisted pair cables with shield. Recommended cable: UL2464, UL2448, etc.
- ✓ The total extension length of the cable is up to 500m. A master station and up to 9 units of the MMC system can be connected per line.
- ✓ Both ends of the cable should be connecting with terminate resistors 100Ω 1/2W.
- ✓ The shield wire of the cable should be grounded at one place on the master station unit side.

### 3.4 MODBUS Communication Protocol

#### 3.4.1 General

The MODBUS serial line is a Master-Slaves protocol. Only one master (at the same time) is connected to the bus, and one or several **MMCs** (9 maximum) are also connected to the same serial bus. A MODBUS communication is always initiated by the master. The **MMC** will never transmit data without receiving a request from the master. The **MMCs** will never communicate with each other. The master initiates only one MODBUS transaction at the same time.

The master issues a MODBUS command message to the **MMCs** in two modes:

1. Unicast Mode: the master addresses an individual **MMC**. After receiving and processing the command message, the **MMC** returns a response message to the master. Each **MMC** must have an unique address (1~9) set by the SW1 switch on the mother board.
2. Broadcast mode: the master can send a command message to all **MMCs**. No response is returned to a broadcast command sent by the master. The broadcast commands are necessarily writing commands. ALL **MMCs** must accept the broadcast for writing function. The address 0 is reserved to identify a broadcast exchange.

#### 3.4.2 Composition of Command Message

Command message and response message consist of 4 fields: Slave Address (ID), Function code, Data and CRC check code. And these are sends in this order. The allowable character transmitted for all fields are hexadecimal 0-9, A-F.

#### RTU message framing

Slave Address	Function Code	Data	CRC
1 byte	1 byte	0 up to 252 byte(s)	2 bytes CRC Low   CRC Hi

In the following, each field is explained.

#### 1. Slave Address (ID)

Address is the number specifying a **MMC**. The individual addresses are set by the SW1 switch in the range of 1-9 decimal. A master addresses a **MMC** by placing the **MMC**

address in the address field of the message. When the **MMC** returns its response, it places its own address in this address field of the response to let the master know which **MMC** is responding.

Address 0 is used for the broadcast address, which all **MMCs** recognize.

When the broadcast address (address 0) is applied on the command message, no any response message will be sent from the **MMC**

## 2. Function Code

This is a code to designate the function executed by **MMC**. When a message is sent from a master to a **MMC**, the function code field tells the **MMC** what kind of action to perform. When the **MMC** responds to the master, it uses the function code field to indicate either a normal response or that some kind of error occurred. For normal response, the **MMC** simply echoes the original function code. For an exception response, the **MMC** returns a code that is equivalent to the original function code with its most-signification bit set to logic 1.

The listing below shows the function codes supported by the **MMC**.

Function code		
Code	Function	Object Type
03	Read-out	16-bit word Read/Write Register
04	Read-out	16-bit word Read Only Register
05	Write-in	Single bit
06	Write-in	16-bit word Read/Write Register
10	Write-in	16-bit word Read/Write Register

## 3. Data

Data are the data required for executing function codes. The composition of data varies with function codes.

A data register is assigned to each parameter in the **MMC**. For reading/writing parameter by communication, designate the data register. Refer to section 4.2 for details.

## 4. CRC check

This is the code to detect message errors (change in bit) in the signal transmission.

On the MODBUS protocol (RTU mode), CRC-16 (Cyclical Redundancy Check) is applied.

CRC-16 is the 2-bytes (16-bits) error check code. From the first byte (address) of the message to the end of the data field are calculated.

The slave station calculates the CRC of the received message, and does not respond if the calculated CRC is different from the contents of the received CRC code.

The Cyclical Redundancy Checking (CRC) field is two bytes, containing a 16-bit binary value. The CRC value is calculated by the transmitting device, which appends the CRC to the message. The device that receives recalculates a CRC during receipt of the message,

and compares the calculated value to the actual value it received in the CRC field. If the two values are not equal, an error results.

The CRC is started by first preloading a 16-bit register to all 1's. Then a process begins of applying successive 8-bit bytes of the message to the current contents of the register. Only the eight bits of data in each character are used for generating the CRC. Start and stop bits and the parity bit, do not apply to the CRC.

During generation of the CRC, each 8-bit character is exclusive ORed with the register contents. Then the result is shifted in the direction of the least significant bit (LSB), with a zero filled into the most significant bit (MSB) position. The LSB is extracted and examined. If the LSB was a 1, the register is then exclusive ORed with a preset, fixed value. If the LSB was a 0, no exclusive OR takes place.

This process is repeated until eight shifts have been performed. After the last (eighth) shift, the next 8-bit character is exclusive ORed with the register's current value, and the process repeats for eight more shifts as described above. The final content of the register, after all the characters of the message have been applied, is the CRC value.

A procedure for generating a CRC is:

1. Load a 16-bit register with FFFF hex (all 1's). Call this the CRC register.
2. Exclusive OR the first 8-bit byte of the message with the low-order byte of the 16-bit CRC registers, putting the result in the CRC register.
3. Shift the CRC register one bit to the right ( toward the LSB ), Zero-filling the MSB. Extract and examine the LSB.
4. If the LSB was 0: Repeat Step 3.  
If the LSB was 1: Exclusive OR the CRC registers with the polynomial value 0xA001 (1010 0000 0000 0001).
5. Repeat step 3 and 4 until 8 shifts have been performed. When this is done, a complete 8-bit byte will have been processed.
6. Repeat step 2 through 5 for the next 8-bit byte of the message. Continue doing this until all bytes have been processed.
7. The final content of the CRC register is the CRC value.
8. When the CRC is placed into the message, its upper and lower bytes must be swapped as described below.

For example, if the CRC value is x1241H ( 0001 0010 0100 0001):

Addr	Func	Data Count	Data	Data	Data	Data	CRC Lo	CRC Hi
							0x41	0x12

### 3.4.3 Response Message of MMC

Once the command message has been processed by the MMC, a response message is built depending on the result of processing.

## 1. Normal Response

To a relevant command message, the MMC creates and sends back a response message, which corresponds to the command message. The composition of response message in this case is the same as command message. Content of the data field depend on the function code. For details, refer to Chapter 6.

## 2. Exception Response

If contents of a command message have an abnormality (for example, non-actual function code is designated) other than transmission error, the slave station does not execute that command but creates and sends back a response message at error detection.

The composition of response message at error detection is shown on below; the value used for function code field is the function code of command message plus x80H.

Slave Address	Function code (Function code + x80H)	Error code	CRC check
8 BITS	8 BITS	8 BITS	16 BITS

Error Code	Contents	Description
01	Illegal function	The function code received is not an allowable action for the slave.
02	Illegal data address	The data address received is not an allowable address for the slave.
03	Illegal data value	A value contained in the data field is not an allowable value for the slave.

### 3.4.4 MODBUS Message RTU Framing

In RTU mode, message frame are separated by a silent interval of at least 3.5 character times. The entire message frame must be transmitted as a continuous stream of characters. If a silent interval of more than 1.5 character times occurs between two characters, the message frame is declared incomplete and will be discarded by the **MMC**.

#### RTU Message Frame

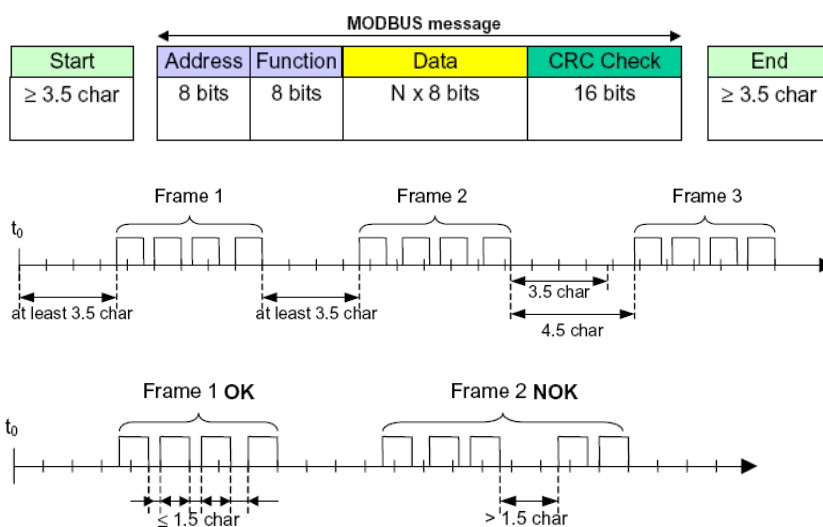

#### 1. Transmission procedure of master station

Since the communication system uses the 2-wire RS-485 interface, there may be 2 statuses on a line below.



- (a) Vacant status (no data on line)
- (b) Communication status (data is existing)

The master station must proceed to a communication upon conforming to the following items.

- 1-1. Before sending a command message, at least 3.5 character times silent interval must be provided.
- 1-2. For sending, the interval between bytes of a command message must be below 1.5 character times.
- 1-3. Within 1.5 character times after sending a command message, the receiving status is posted.
- 1-4. Provide 3.5 character times vacant status between the end of response message reception and beginning of next command message sending (same as in 1-1).
- 1-5. For ensuring the safety, make a confirmation of the response message and make an arrangement so as to provide 3 or more retries in case of no response, error occurrence, etc.

## 2. Transaction of The MMC

### (1) Detection of the command message frame

The **MMCs** connected on the line are initially at a receiving status and monitoring the line. When 1.5 character times or more vacant status has appeared on the line, the end of preceding frame is assumed and, within following 1.5 character times, a receiving status is posted. When data appears on the line, the **MMCs** receive it. While 1.5 character times more vacant status is detected again, the end of that frame is assumed. Data, which appeared on the line from the first 3.5 character times or more vacant status to the next 3.5 character times or more vacant status, is fetched as one frame.

### (2) Response of **MMC**

After frame detection, The **MMC** carries out that frame as a command message. If the command message is destined to the own station, a response message is returned. Its processing time is 1 to 10ms (depends on contents of command message). After sending a command message, therefore, the master station must observe the following.

- 1-1. Receiving status is posted within 1.5 character times after sending a command message.
- 1-2. 3.5 character times or more vacant status precedes the response message sending.
- 1-3. Interval between bytes of response message must be smaller than 1.5 character times.

### 3.5 Function Code Description

#### 3.5.1 Read Data Registers [Function Code: 03]

Read the contents of a contiguous block of data registers in the MMC.

**Broadcast is not possible.**

##### 1. Message composition

Command message composition

Address	Function Code	Starting Register	Quantity of Registers	CRC-16	
x01~x09	x03	x0000~xFFFF	x0001~x007D	Low-order byte	High-order byte
1 byte	1 byte	2 byte	2 bytes	2 bytes	

Response message composition

Address	Function Code	Byte Count *	Register Value	CRC-16	
x01~x09	x03	x02~xFA		Low-order byte	High-order byte
1 byte	1 byte	1 bytes	N x 2 bytes	2 bytes	

\* N = Quantity of Registers; Byte Count = N × 2

##### 2. Message transmission (example)

The following show an example of reading the set-point of channel 1 [data register x0000] from address No.1.

Command message composition

Address	Function Code	Starting Register	Quantity of Registers	CRC-16	
x01	x03	x0000	x0001	x840A	

Response message composition

Address	Function Code	Byte Count	Register Value	CRC-16
x01	x03	x02	x03E8	xB8FA

The response data show that the set-point of channel 1 is x03E8 (1000).

#### 3.5.2 Read Input Registers [Function Code: 04]

Read the contents of a contiguous block of input registers (x1000~x1FFF) in the MMC.

Broadcast is not possible.

##### 1. Message composition

Command message composition

Address	Function Code	Starting Register	Quantity of Registers	CRC-16	
x01~x09	x04	x1000~x1FFF	x0001~x007D	Low-order byte	High-order byte
1 byte	1 byte	2 bytes	2 bytes	2 bytes	

Response message composition

Address	Function Code	Byte Count *	Register Value	CRC-16	
x01~x09	x04	x02~xFA		Low-order byte	High-order byte
1 byte	1 byte	1 byte	N x 2 bytes	2 bytes	

\* N = Quantity of Registers; Byte Count = N × 2

## 2. Message transmission (example)

The following show an example of reading the Process Value (PV) of channel 1 [Input register x1000] from address No.1.

Command message composition

Address	Function Code	Starting Register	Quantity of Registers	CRC-16	
x01	x04	x1000	x0001	x350A	

Response message composition

Address	Function Code	Byte Number	Register Value	CRC-16	
x01	x04	x02	x001B	xF93B	

The response data show that the Process Value (PV) of channel 1 is x001B (27).

### 3.5.3 Write Single Coil [Function Code: 05]

Set the EEPROM write-in flag to save parameters setting into non-volatile memory in the MMC.

The built-in non-volatile memory (EEPROM) in the MMC has 1 million guaranteed rewrite cycles. To prevent the EEPROM be written frequently, the parameters written by communication with Function Code x06 and x10 are kept in the internal memory (RAM) instead of in the EEPROM.

Please note that all those data without saving in the EEPROM will be lost after turning off the power.

The MMC will reset the EEPROM write-in flag automatically after saving all those RAM data into EEPROM.

Broadcast is possible

#### 1. Message composition

Command message composition

Address	Function	Register Address	Register Value	CRC-16	
x01~x09	x05	x0000	xFF00	Low-order byte	High-order byte
1 byte	1 byte	2 bytes	2 bytes	2 bytes	

Response message composition

Address	Function	Register Address	Register Value	CRC-16	
x01~x09	x05	x0000	xFF00	Low-order byte	High-order byte
1 byte	1 byte	2 bytes	2 bytes	2 bytes	

#### 2. Message transmission (example)

The following show an example of setting the EEPROM write-in flag.

Command message composition

Address	Function Code	Register Address	Register Value	CRC-16	
x01	x05	x0000	xFF00	x8C3A	

Response message composition

Address	Function Code	Register Address	Register Value	CRC-16	
x01	x05	x0000	xFF00	x8C3A	

After the transmission, the MMC save the RAM data into EEPROM and reset the EEPROM write-in flag.

### 3.5.4 Write Single Register [Function Code: 06]

Write a single data register (x0000~xFFFF) in the MMC.

Please note that the register value will not be retained after power off until the EEPROM write-in flag is set with function code x05.

Broadcast is possible

#### 1. Message composition

Command message composition

Address	Function	Register Address	Register Value	CRC-16	
x01~x09	x06	x0000~xFFFF		Low-order byte	High-order byte
1 byte	1 byte	2 bytes	2 bytes	2 bytes	

Response message composition

Address	Function	Register Address	Register Value	CRC-16	
x01~x09	x06	x0000~xFFFF		Low-order byte	High-order byte
1 byte	1 byte	2 bytes	2 bytes	2 bytes	

#### 2. Message transmission (example)

The following show an example of setting the Input signal type [data register x0024] of address No.1 to K type thermocouple.

Command message composition

Address	Function Code	Register Address	Register Value	CRC-16	
x01	x06	x0024	X0001	x0801	

Response message composition

Address	Function Code	Register Address	Register Value	CRC-16	
x01	x06	x0024	x0001	x0801	

### 3.5.5 Write Multiple Registers [Function Code: 10]

Write a block of contiguous data registers in the MMC.

Please note that these register values will not be retained after power off until the EEPROM write-in flag is set with function code x05.

Broadcast is possible

#### 1. Message composition

Command message composition

Address	Function Code	Starting Register	Quantity of Registers	Byte Count*	Registers Value	CRC-16	
x01~x09	x10	x0000~xFFFF	x0001~x007B	N x 2		Low-order byte	High-order byte
1 byte	1 byte	2 bytes	2 bytes	1 byte	N x 2	2 bytes	

\* N = Quantity of Registers; Byte Count = N x 2

Response message composition

Address	Function Code	Starting Register	Quantity of Registers	CRC-16	
x01~x09	x10	x0000~xFFFF	x0001~x007B	Low-order byte	High-order byte
1 byte	1 byte	2 bytes	2 bytes	2 bytes	

## 2. Message transmission (example)

The following show an example of setting the low limit [data register x002B] to 0 (x0000) and high limit [data register x002C] to 1000 (x03E8) in address No.1.

Command message composition

Address	Function Code	Starting Register	Quantity of Registers	Byte Count	Register Value	Register Value	CRC-16
x01	x10	x002B	x0002	x04	x0000	x03E8	xB0BA

Response message composition

Address	Function Code	Starting Register	Quantity of Registers	CRC-16
x01	x10	x002B	x0002	x31C0

## 4 Parameters Description and Data Register Map

### 4.1 Parameters Description

#### 4.1.1 User

##### 1. SV (Set-Point)

Description: The Set-Point is the target of the controlled process.

Range: High limit ~ Low limit

Unit: °C, °F or Engineering unit

##### 2. Ramp (Ramp rate)

Description: The controller can act as either a fixed set point controller or as a single ramp controller. If the ramp rate is set to a value other than "0", the process will increase or decrease at the setting rate during initial power up or with set point change.

Range: 0 ~ 30000

Unit: °C, °F or Engineering unit per Min.

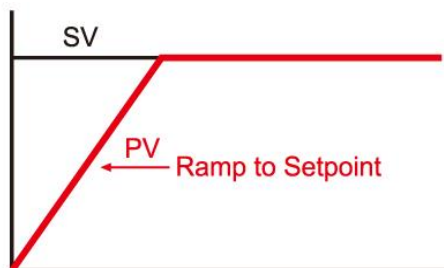

##### 3. Soft (Soft start time)

Description: Soft start time can be programmed in situation where 100% output is prohibited at power up to prevent the damage of heating element. The time duration for

the output to rise from 0% to 100% is programmed as soft start time

Range: 0 ~ 30000

Unit: Seconds.

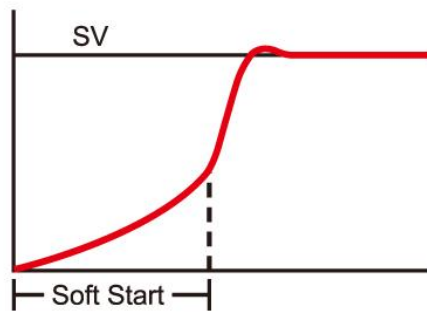

**4. Hout (Heating output)**

Description: Set the heating output percentage of manual mode.

Range: 0.0 ~ 100.0

Unit: %

**5. Cout (Cooling output)**

Description: Set the cooling output percentage of manual mode.

Range: 0.0 ~ 100.0

Unit: %

**6. Run**

Description: Select the PID controller running mode.

Range: 0 ~ 6

Unit: N/A

Setting	Mode	Action
0	Standby mode	Both heating and cooling output are turned off.
1	Auto mode (closed loop control)	Run the PID controller with fixed set-point. The control output is determined by PID algorithm or ON/OFF action.
2	Auto-tuning mode 1	<p>The controller will tune the PID parameters automatically at SV. The process will oscillate around the SV during AT1 process. Use AT2 mode if overshooting beyond the normal process is likely to cause damage.</p>
3	Auto-tuning mode 2	The controller will tune the PID parameters automatically at 90% of SV. The process will oscillate

		<p>around (90%SV) during AT2 process.</p>
4	Manual mode (open loop control)	In this mode, the heating and cooling output are set manually by “Hout” and “Cout” separately.
5	Profile mode	Run the profile set in the program parameters.
6	Pause mode	The SV will be held at the moment the pause mode is set.

#### 4.1.2 Level PID

There are 4 independent level PID parameters available for different set-point. This is useful when the control process needs to change its set-point within a wide range.

##### 1. **Pb1 / Pb2 / Pb3 / Pb4 (Proportional Band)**

Description: Set the proportional band in percentage of SPAN (High limit – Low limit). It can be set automatically by auto-tuning process. Set to 0.0 for ON/OFF control mode.

Range: 0.0 ~ 300.0

Unit: %

##### 2. **Ti1 / Ti2 / Ti3 / Ti4 (Integral Time)**

Description: Set the integral time. This value can be automatically calculated by activating the auto tune function. If desired, the user can later adjust this parameter to better suit the application. When Pb=0.0 (On/Off control mode), this parameter will be not available.

Range: 0 ~ 3000

Unit: Second

##### 3. **Td1 / Td2 / Td3 / Td4 (Derivative Time)**

Description: Set the derivate time. This value can be automatically calculated by activating the auto tune function. If desired, the user can later adjust this parameter to better suit the application. When Pb=0.0 (On/Off control mode), this parameter will be not available.

Range: 0 ~ 750

Unit: Second

##### 4. **MR1 / MR2 / MR3 / MR4 (Manual Reset)**

Description: For PID control, this value is set automatically after auto-tuning process. For P control, it is used to compensate the deviation between process value and set point.

Range: 0.0 ~ 51.0

Unit: %.

##### 5. **AR1/AR2/AR3/AR4 (Anti-Reset Windup)**

Description: The Anti-Reset windup (ARW) inhibits the integral action until the PV is within

the ARW band thus reducing overshoot on start-up. It is set automatically by auto-tuning process. It is set in percentage of proportional band.

Range: 0.0 ~ 100.0

Unit: %.

**6. CPb1/CPb2/CPb3/CPb4 ( Proportional Band )**

Description: Set the cooling proportional band in percentage of SPAN (High limit – Low limit). It can be set automatically by auto-tuning process. Set to 0.0 for ON/OFF control mode.

Range: 0.0 ~ 300.0

Unit: %

**7. ASP1/ASP2/ASP3 (Level PID boundary)**

Description: Set the level PID boundary. The level 1 PID parameters (Pb1, Ti1, Td1, MR1, AR1 and CPb1) will be applied when the set-point is below ASP1. The level 2 PID parameters (Pb2, Ti2, Td2, MR2, AR2 and CPb2) are applied when the set-point is between ASP1 and ASP2. The level 3 PID parameters (Pb3, Ti3, Td3, MR3, AR3 and CPb3) are applied when the set-point is between ASP2 and ASP3. The level 4 PID parameters (Pb4, Ti4, Td4, MR4, AR4 and CPb4) are applied when the set-point is higher than ASP3.

Range: High limit ~ Low limit

Unit: °C, °F or Engineering unit.

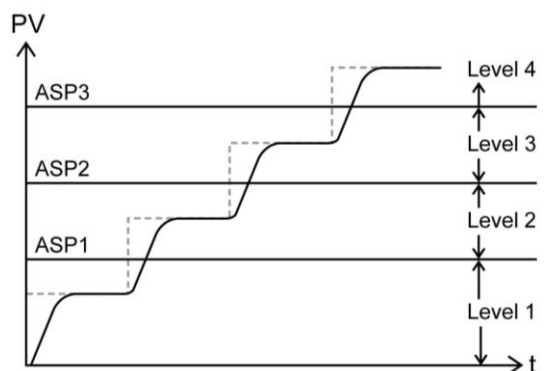

**8. Hys (Hysteresis of heating output)**

Description: With ON/OFF control, the control output turns On/Off with respect to the set point. Therefore, the control output would change frequently in response to a slight change in process value. This might shorten the service life of the output device. To prevent this, a hysteresis is provided in the ON/OFF control.

Range: 0 ~ 30000

Unit: °C, °F or Engineering unit

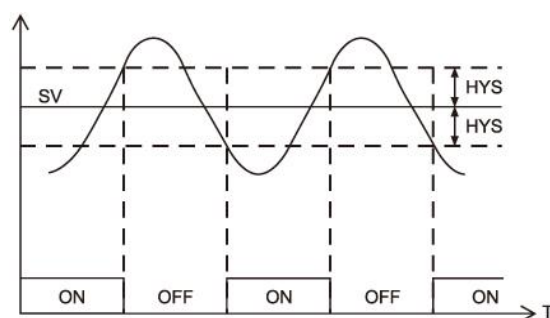



### 9. CHys (Hysteresis of cooling output)

Description: The hysteresis applied on cooling output.

Range: 0 ~ 30000

Unit: °C, °F or Engineering unit

### 10. DB (Dead Band)

Description: this setting defines the area in which both heating and cooling outputs are inactive, known as dead band, or the area in which they are both active, known as overlap. A positive value results in a dead band, while a negative value results in an overlap.

Range: -30000 ~ 30000

Unit: °C, °F or Engineering unit

## 4.1.3 Option

### 1. Type (Input Signal Type)

Description: Select the input signal type.

Range: 0 ~ 13

Unit: N/A

Setting	Type	Max. measuring range
0	J	-50 ~ 1000°C
1	K	-50 ~ 1370°C
2	T	-270 ~ 400°C
3	E	-50 ~ 950°C
4	B	0 ~ 1800°C
5	R	-50 ~ 1750°C
6	S	-50 ~ 1750°C
7	N	-50 ~ 1300°C
8	C	-50 ~ 1800°C
9	PT100 (DIN)	-200 ~ 850°C
10	PT100 (JIS)	-200 ~ 600°C
11	mA	-30000 ~ 30000 count
12	mV	-30000 ~ 30000 count
13	V	-30000 ~ 30000 count

### 2. SCAL (Low Scale of Linear Input)

Description: Set the low scale corresponding to low linear input signal (see the cut-off function for further detail). This parameter is effective only for linear input (mA, mV and V) type.

Range: 0 ~ 30000

Unit: Count

### 3. SCAH (High Scale of Linear Input)

Description: Set the high scale corresponding to high linear input signal (see the cut-off function for further detail). This parameter is effective only for linear input (mA, mV and V) type.

Range: 0 ~ 30000

Unit: Count

#### 4. Cut (Cut-off Function)

Description: The Cut-off function is used to limit the process value of linear input signal within the boundary whenever the input signal is out of the high/low limit range (set by HiLt and LoLt). The cut-off function can be set to “Low”, “High” or “High/Low”, set to “None” disables the cut-off function. The cut-off function has no effect for input signal other than linear input.

Range: 0 ~ 3

Unit: N/A

Setting	Action
0	None
1	Low
2	High
3	High and Low

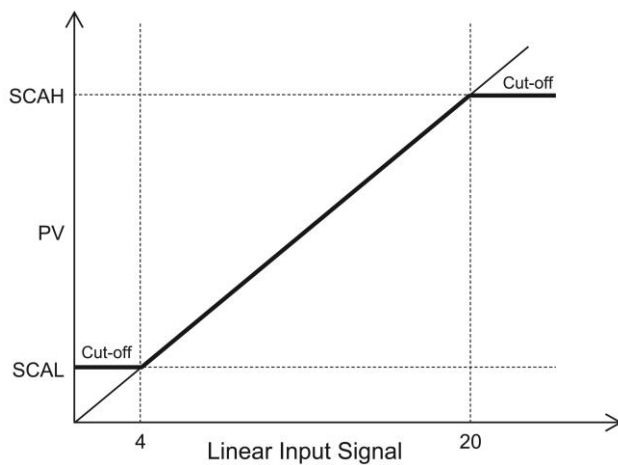

$$PV \text{ scale calculation: } PV = \frac{IN - INL}{INH - INL} (SCAH - SCAL) + SCAL$$

Where

*IN* : the linear input signal.

*INH* : the high calibration of linear input signal. It is set in calibration parameters (mAL, mVL and VL).

*INL* : the low calibration of linear input signal. It is set in calibration parameters (mAH, mVH and VH).

Example:

For a 4~20mA input signal, the INL is set by mAL=4.00mA and the INH is set by mAH=20.00mA ( “mAL” and “mAH” are the calibration parameters, please refer to section **4.1.6 Calibration** ). Set SCAL=0.0 SCAH=100.0 (Of course, you may select other scale value and decimal point to alter the resolution) and LoLt=0.0 HiLt=100.0.

For a 12mA input, the PV will be 50.0.

For a 22mA input, the PV will be 112.5 with cut-off function set to “None” or 100.0 with cut-off function set to “High” or “High/Low”.

For a 0mA input, the PV will be -25.0 with cut-off function set to “None” or 0.0 with cut-off function set to “Low” or “High/Low”

**5. Unit**

Description: Select the process value indication in °C or °F when the input signal type is set to thermocouple or PT100. Select engineering unit for linear input (mA, mV or V).

Range: 0 ~ 2

Unit: N/A

Setting	Unit
0	°C
1	°F
2	Engineering unit

**6. DP (Decimal Point)**

Description: Select the decimal point position.

Range: 0 ~ 3. The setting 2 and 3 is available for linear input only.

Unit: N/A

Setting	Decimal Point
0	0000
1	000.0
2	00.00
3	0.000

**7. Act (Control Action of Output 1)**

Description: Set the output 1 to be heating or cooling action.

Range: 0 or 1

Unit: N/A

Setting	Action
0	Direct action (Cooling)
1	Reverse action (Heating)

**8. LoLt (Low Limit)**

Description: Set the low limit of measuring range. When the PV goes below the low limit, an error flag set and the control outputs are set according to the EROP (Error Protection).

Range: refer to the type description

Unit: °C, °F or Engineering unit

**9. HiLt (High Limit)**

Description: Set the high limit of measuring range. When the PV goes beyond the high limit, an error flag set and the control outputs are set according to the EROP (Error Protection).

Range: refer to the type description

Unit: °C, °F or Engineering unit

**10. FiLt (Digit Filter)**

Description: Set the time constant for digit filter (the first order filter). It is useful when the process value is too unstable to be read.

Range: 0.0 ~ 99.9

Unit: Second

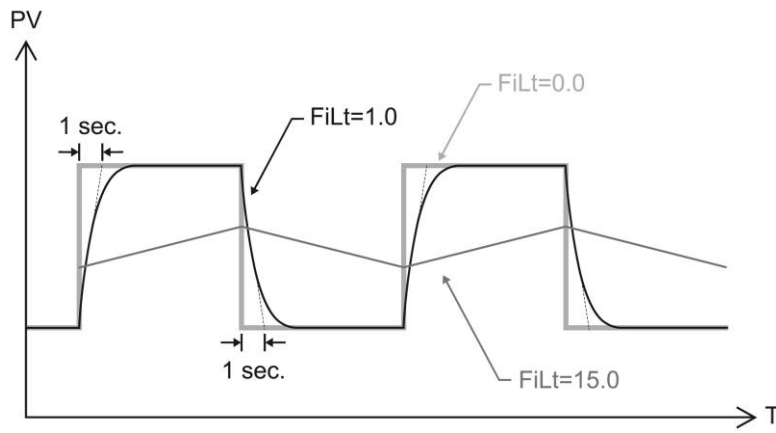

### 11. PTME

Description: Set the time scale used for alarm delay time and ramp rate.

Range: 0 ~ 1

Unit: N/A

Setting	Action
0	The ramp rate is in per second and the ramp and soak time of profile is in second.
1	The ramp rate is in per minute and the ramp and soak time of profile is in minute.

### 12. EROP (Error Protection)

Description: Set the control output status whenever an error occurred

Range: 0 ~ 3

Unit: N/A

Setting	Action
0	Output 1 OFF and Output 2 OFF
1	Output 1 ON and Output 2 OFF
2	Output 1 OFF and Output 2 ON
3	Output 1 ON and Output 2 ON

### 13. SPOF (Set-Point offset)

Description: Shift the set point value with an offset. The actual control target is shifted with this offset from set point value but not added to SV display.

Range: -30000 ~ 30000

Unit: °C, °F or Engineering unit

### 14. PVOF (Process Value offset correction)

Description: Shift the PV with an offset to correct the sensor offset error.

Range: -30000 ~ 30000

Unit: °C, °F or Engineering unit

### 15. PVGA (Process Value gain correction)

Description: Process Value gain correction

Range: 0.0000 ~ 2.0000

Unit: N/A

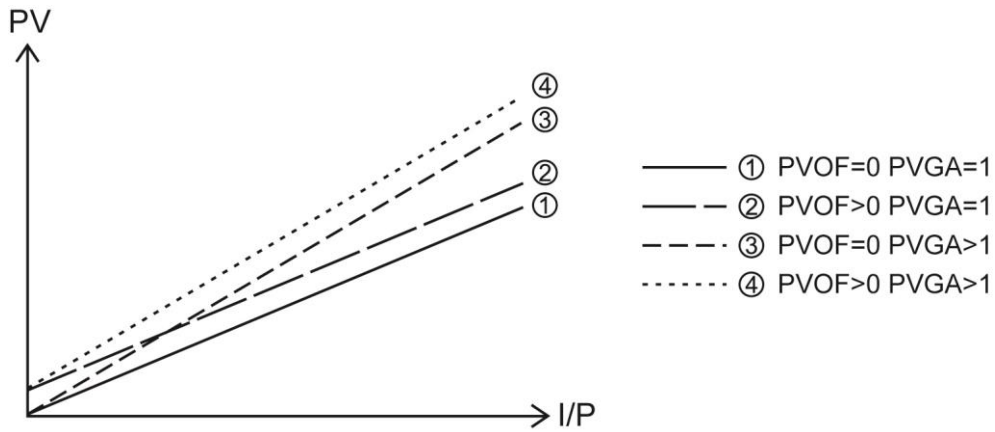

#### 4.1.4 Control Output

##### 1. 01CT / 02CT

Description: Set the control output 1 (01CT) and output 2 (02CT) cycle time. Set to 0 for linear output, 1 for pulsed voltage to drive SSR and 15 for relay output.

Range: 0 ~ 60

Unit: Second

##### 2. 01CH / 02CH

Description: Linear output high scale adjustment.

Range: 0 ~ 8000

Unit: N/A

##### 3. 01CL / 02CL

Description: Linear output low scale adjustment.

Range: 0 ~ 8000

Unit: N/A

##### 4. 01UH / 02UH

Description: Control output 1 and control output 2 high limit.

Range: 0 ~ 100.0

Unit: %

##### 5. 01UL / 02UL

Description: control output 1 and control output 2 low limit

Range: 0 ~ 100.0

Unit: %

#### 4.1.5 Program

##### 1. STAT (State)

Description: The state of power failure for profile execution. Set to 0, the profile will be started from segment 1 while the power is recovered. Set to 1, the profile will be continued from where the profile had been interrupted by power failure while the power is recovered.

Range: 0 or 1

Unit: N/A

**2. STAR (Start)**

Description: Define the segment 1 of profile starting from. Set to 0, the segment 1 will start from 0. Set to 1, it will start from the PV of the instant that profile is execution.

Range: 0 or 1

Unit: N/A

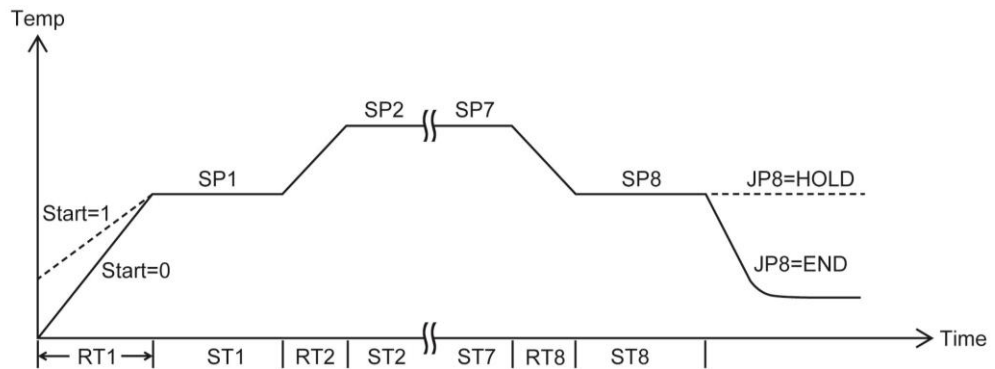

**3. Band**

Description: Set a tolerance band. The soak time start to count down when the PV reaches the band.

Range: 0 ~ 30000

Unit: °C, °F or Engineering unit

**4. RT1~RT8 (Ramp Time)**

Description: Set the time that the process will take to ramp up/down to next segment set-point.

Range: 0 ~ 30000

Unit: Second

**5. SP1~SP8 (Set-Point of segment)**

Description: Segment set-point.

Range: Low limit ~ High limit

Unit: °C, °F or Engineering unit

**6. ST1~ST8 (Soak Time)**

Description: Set the soak time that the PV will remain at the segment set-point.

Range: 0 ~ 30000

Unit: Second

**7. JP1~JP8 (Jump Function)**

Description: Select which segment will be jump to after soak time is up or set the end of the profile.

Range: 0 ~ 10. 10 is not available for JP8

Unit:

Setting	Action
0	End of the profile
1	Jump to Segment 1
2	Jump to Segment 2
3	Jump to Segment 3

<b>4</b>	<b>Jump to Segment 4</b>
<b>5</b>	<b>Jump to Segment 5</b>
<b>6</b>	<b>Jump to Segment 6</b>
<b>7</b>	<b>Jump to Segment 7</b>
<b>8</b>	<b>Jump to Segment 8</b>
<b>9</b>	<b>Hold. PV will be hold at the segment set-point</b>
<b>10</b>	<b>Next. Link to next segment</b>

### 8. LN1~LN8 (Loop Number)

Description: In coordinate with jump function. Set the cycle number that the profile loop will be executed.

Range: 0 ~ 30001. 30001 will have unlimited cycles.

Unit: N/A

An example is shown in figure 6 below. Here the JP3 is set to 2 and LN3 is set to 0. When the segment 3 is completed, the profile will jump to segment 2, and proceed to segment 3 again. Because the LN3 is set to 0, after the second time that segment 3 is completed, the profile will proceed to segment 4.

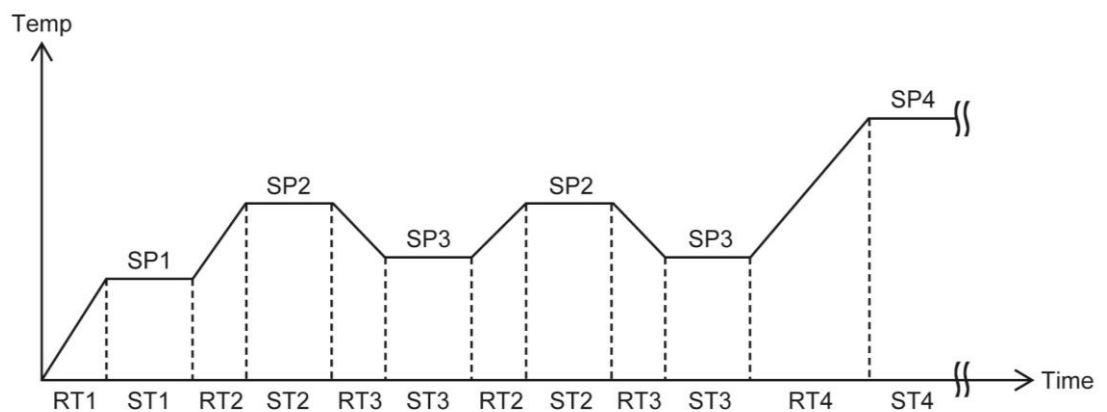

Figure 6 JP3=2 and LN3=0

Another example is shown in figure 7 below. Here the JP3 is set to 2 and LN3 is set to 1. When the segment 3 is completed, the profile will jump to segment 2, and proceed to segment 3 again. Because the LN3 is set to 1, so the profile will excuse the loop once again until the third time that segment 3 is completed, the profile proceed to segment 4.

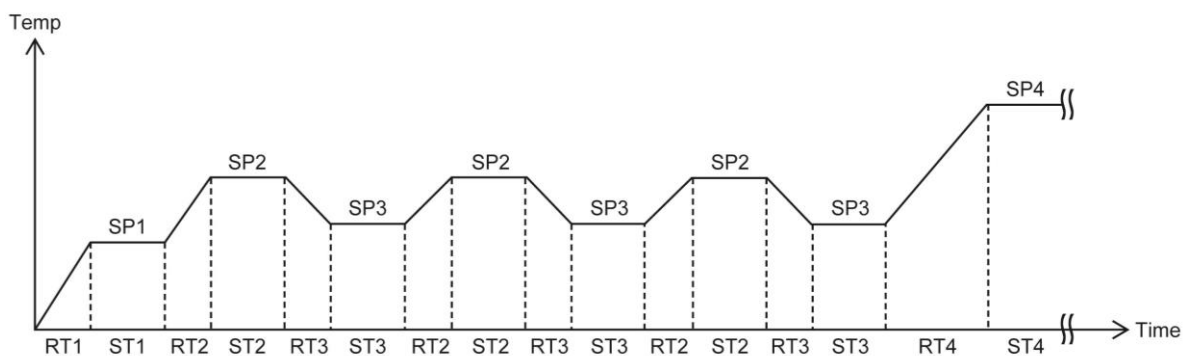

Figure 7 JP3=2 and LN3=1

#### 4.1.6 Calibration

The following parameters are for calibration purpose only. Do not change its setting unless you are familiar with calibration procedure

**1. RTDL**

Description: Low calibration of RTD input.

Range: -200.0 ~ 850.0

Unit: °C

**2. RTDH**

Description: High calibration of RTD input.

Range: -200.0 ~ 850.0

Unit: °C

**3. mAL**

Description: Low calibration of milliamp input signal. The setting value will correspond to SCAL for PV scale.

Range: -25.00 ~ 25.00

Unit: mA

**4. mAH**

Description: High calibration of milliamp input signal. The setting value will correspond to SCAH for PV scale.

Range: -25.00 ~ 25.00

Unit: mA

**5. mVL**

Description: Low calibration of millivolt input signal. The setting value will correspond to SCAL for PV scale.

Range: -65.00 ~ 65.00

Unit: mV

**6. mVH**

Description: High calibration of millivolt input signal. The setting value will correspond to SCAH for PV scale.

Range: -65.00 ~ 65.00

Unit: mV

**7. VL**

Description: Low calibration of voltage input signal. The setting value will correspond to SCAL for PV scale.

Range: -10.00 ~ 10.00

Unit: V

**8. VH**

Description: High calibration of voltage input signal. The setting value will correspond to SCAH for PV scale.

Range: -10.00 ~ 10.00

Unit: V





2. ALSP (Alarm Set-Point)

Description: The set-point of alarm even.

Range:

Unit: °C, °F or Engineering unit

3. ALFU (Alarm Function)

Description: Select the alarm function

Range: 0 ~ 15

Setting	Alarm Function	Action (Form A Contact)
0 / 8	Manual	Alarm is set or reset by the setting of ALFG register. Initial status is off.
1 / 9	Manual	Alarm is set or reset by the setting of ALFG register. Initial status is on.
2 / 10	Process High Alarm	
3 / 11	Process Low Alarm	
4 / 12	Deviation High Alarm	
5 / 13	Deviation Low Alarm	
6 / 14	Deviation Band High Alarm	
7 / 15	Deviation Band Low Alarm	

Unit: N/A

4. ALHY (Alarm Hysteresis)

Description: The hysteresis of alarm action

Range: 0 ~ 30000

Unit: °C, °F or Engineering unit

5. ALMD (Alarm Mode)

Description: Select the alarm mode.

Range: 0 ~ 3

Setting	Alarm Mode	Action
0	Normal Mode	
1	Standby Mode	Prevents an alarm on power up. The alarm is active after alarm condition has been cleared and then alarm occurs again.
2	Latch Mode	The alarm output will be latched as the alarm occurs. The alarm output will not change its state even if the alarm condition has been cleared unless the power is off.
3	Standby & Latch mode	Both standby and Latch mode are applied.

Unit: N/A

The alarm action for deviation band high alarm with different alarm mode is shown below.

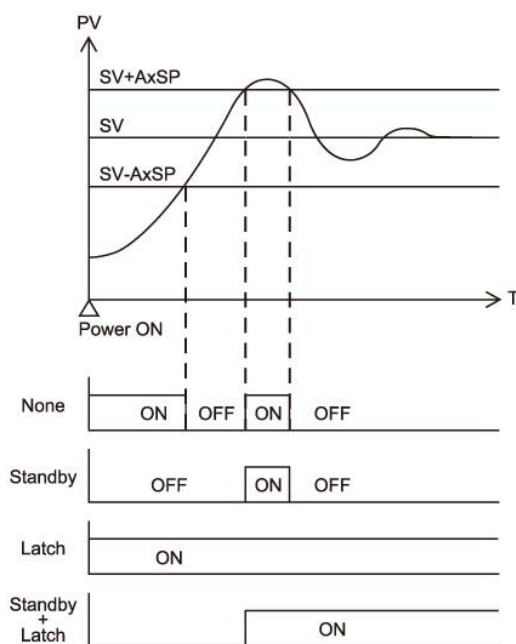

#### 6. ALDT (Alarm Delay Time)

Description: Alarm delay time is set to postpone the alarm action by the setting time.

Range: 0 ~ 30000

Unit: Second

#### 7. ALFG1/ALFG2 (Alarm Status Flag)

Description: The alarm status flag register. Each bit of the register indicates the status of alarm even. The bit is set to "1" when the alarm is turned on and is reset to "0" when the alarm is turned off. It is read/write available if the ALFU is set to "manual". Otherwise, it is read only.

Bit	15	14	13	12	11	10	9	8	7	6	5	4	3	2	1	0
ALFG1	A16	A15	A14	A13	A12	A11	A10	A9	A8	A7	A6	A5	A4	A3	A2	A1

Bit	15	14	13	12	11	10	9	8	7	6	5	4	3	2	1	0
ALFG2	A32	A31	A30	A29	A28	A27	A26	A25	A24	A23	A22	A21	A20	A19	A18	A17

Range: 0 or 1 for each bit

Unit: N/A

## 4.3 Data Register Map

### 4.3.1 Controller Registers

■ Table of Data Registers : Function code [03,06] Word data (read-out/write-in)

Register		Channel							
Parameter	Read/Write	#1	#2	#3	#4	#5	#6	#7	#8
<b>USER</b>									
<b>SV</b>	R/W	x0000	x0080	x0100	x0180	x0200	x0280	x0300	x0380
<b>Ramp</b>	R/W	x0001	x0081	x0101	x0181	x0201	x0281	x0301	x0381
<b>Soft</b>	R/W	x0002	x0082	x0102	x0182	x0202	x0282	x0302	x0382
<b>Hout</b>	R/W	x0003	x0083	x0103	x0183	x0203	x0283	x0303	x0383
<b>Cout</b>	R/W	x0004	x0084	x0104	x0184	x0204	x0284	x0304	x0384
<b>Run</b>	R/W	x0005	x0085	x0105	x0185	x0205	x0285	x0305	x0385
<b>PID</b>									
<b>Pb1</b>	R/W	x0006	x0086	x0106	x0186	x0206	x0286	x0306	x0386
<b>Ti1</b>	R/W	x0007	x0087	x0107	x0187	x0207	x0287	x0307	x0387
<b>Td1</b>	R/W	x0008	x0088	x0108	x0188	x0208	x0288	x0308	x0388
<b>Mr1</b>	R/W	x0009	x0089	x0109	x0189	x0209	x0289	x0309	x0389
<b>Ar1</b>	R/W	x000A	x008A	x010A	x018A	x020A	x028A	x030A	x038A
<b>CPb1</b>	R/W	x000B	x008B	x010B	x018B	x020B	x028B	x030B	x038B
<b>ASP1</b>	R/W	x000C	x008C	x010C	x018C	x020C	x028C	x030C	x038C
<b>Hys</b>	R/W	x000D	x008D	x010D	x018D	x020D	x028D	x030D	x038D
<b>CHys</b>	R/W	x000E	x008E	x010E	x018E	x020E	x028E	x030E	x038E
<b>DB</b>	R/W	x000F	x008F	x010F	x018F	x020F	x028F	x030F	x038F
<b>Pb2</b>	R/W	x0010	x0090	x0110	x0190	x0210	x0290	x0310	x0390
<b>Ti2</b>	R/W	x0011	x0091	x0111	x0191	x0211	x0291	x0311	x0391
<b>Td2</b>	R/W	x0012	x0092	x0112	x0192	x0212	x0292	x0312	x0392
<b>Mr2</b>	R/W	x0013	x0093	x0113	x0193	x0213	x0293	x0313	x0393
<b>Ar2</b>	R/W	x0014	x0094	x0114	x0194	x0214	x0294	x0314	x0394
<b>CPb2</b>	R/W	x0015	x0095	x0115	x0195	x0215	x0295	x0315	x0395
<b>ASP2</b>	R/W	x0016	x0096	x0116	x0196	x0216	x0296	x0316	x0396
<b>Pb3</b>	R/W	x0017	x0097	x0117	x0197	x0217	x0297	x0317	x0397
<b>Ti3</b>	R/W	x0018	x0098	x0118	x0198	x0218	x0298	x0318	x0398
<b>Td3</b>	R/W	x0019	x0099	x0119	x0199	x0219	x0299	x0319	x0399
<b>Mr3</b>	R/W	x001A	x009A	x011A	x019A	x021A	x029A	x031A	x039A
<b>Ar3</b>	R/W	x001B	x009B	x011B	x019B	x021B	x029B	x031B	x039B
<b>CPB3</b>	R/W	x001C	x009C	x011C	x019C	x021C	x029C	x031C	x039C
<b>ASP3</b>	R/W	x001D	x009D	x011D	x019D	x021D	x029D	x031D	x039D

<b>Pb4</b>	R/W	x001E	x009E	x011E	x019E	x021E	x029E	x031E	x039E
<b>Ti4</b>	R/W	x001F	x009F	x011F	x019F	x021F	x029F	x031F	x039F
<b>Td4</b>	R/W	x0020	x00A0	x0120	x01A0	x0220	x02A0	x0320	x03A0
<b>Mr4</b>	R/W	x0021	x00A1	x0121	x01A1	x0221	x02A1	x0321	x03A1
<b>Ar4</b>	R/W	x0022	x00A2	x0122	x01A2	x0222	x02A2	x0322	x03A2
<b>CPb4</b>	R/W	x0023	x00A3	x0123	x01A3	x0223	x02A3	x0323	x03A3
<b>OPTION</b>									
<b>Type</b>	R/W	x0024	x00A4	x0124	x01A4	x0224	x02A4	x0324	x03A4
<b>SCAL</b>	R/W	x0025	x00A5	x0125	x01A5	x0225	x02A5	x0325	x03A5
<b>SCAH</b>	R/W	x0026	x00A6	x0126	x01A6	x0226	x02A6	x0326	x03A6
<b>Cut</b>	R/W	x0027	x00A7	x0127	x01A7	x0227	x02A7	x0327	x03A7
<b>Unit</b>	R/W	x0028	x00A8	x0128	x01A8	x0228	x02A8	x0328	x03A8
<b>Dp</b>	R/W	x0029	x00A9	x0129	x01A9	x0229	x02A9	x0329	x03A9
<b>Act</b>	R/W	x002A	x00AA	x012A	x01AA	x022A	x02AA	x032A	x03AA
<b>LoLt</b>	R/W	x002B	x00AB	x012B	x01AB	x022B	x02AB	x032B	x03AB
<b>HiLt</b>	R/W	x002C	x00AC	x012C	x01AC	x022C	x02AC	x032C	x03AC
<b>FiLt</b>	R/W	x002D	x00AD	x012D	x01AD	x022D	x02AD	x032D	x03AD
<b>PTME</b>	R/W	x002E	x00AE	x012E	x01AE	x022E	x02AE	x032E	x03AE
<b>EROP</b>	R/W	x002F	x00AF	x012F	x01AF	x022F	x02AF	x032F	x03AF
<b>SPOF</b>	R/W	x0030	x00B0	x0130	x01B0	x0230	x02B0	x0330	x03B0
<b>PVOF</b>	R/W	x0031	x00B1	x0131	x01B1	x0231	x02B1	x0331	x03B1
<b>PVSE</b>	R/W	x0032	x00B2	x0132	x01B2	x0232	x02B2	x0332	x03B2
<b>CONTROL OUTPUT</b>									
<b>01CT</b>	R/W	x0033	x00B3	x0133	x01B3	x0233	x02B3	x0333	x03B3
<b>01CH</b>	R/W	x0034	x00B4	x0134	x01B4	x0234	x02B4	x0334	x03B4
<b>01CL</b>	R/W	x0035	x00B5	x0135	x01B5	x0235	x02B5	x0335	x03B5
<b>01UH</b>	R/W	x0036	x00B6	x0136	x01B6	x0236	x02B6	x0336	x03B6
<b>01UL</b>	R/W	x0037	x00B7	x0137	x01B7	x0237	x02B7	x0337	x03B7
<b>02CT</b>	R/W	x0038	x00B8	x0138	x01B8	x0238	x02B8	x0338	x03B8
<b>02CH</b>	R/W	x0039	x00B9	x0139	x01B9	x0239	x02B9	x0339	x03B9
<b>02CL</b>	R/W	x003A	x00BA	x013A	x01BA	x023A	x02BA	x033A	x03BA
<b>02UH</b>	R/W	x003B	x00BB	x013B	x01BB	x023B	x02BB	x033B	x03BB
<b>02UL</b>	R/W	x003C	x00BC	x013C	x01BC	x023C	x02BC	x033C	x03BC
<b>PROGRAM</b>									
<b>STAT</b>	R/W	x003D	x00BD	x013D	x01BD	x023D	x02BD	x033D	x03BD
<b>STAR</b>	R/W	x003E	x00BE	x013E	x01BE	x023E	x02BE	x033E	x03BE
<b>BAND</b>	R/W	x003F	x00BF	x013F	x01BF	x023F	x02BF	x033F	x03BF
<b>RT1</b>	R/W	x0040	x00C0	x0140	x01C0	x0240	x02C0	x0340	x03C0
<b>SP1</b>	R/W	x0041	x00C1	x0141	x01C1	x0241	x02C1	x0341	x03C1
<b>ST1</b>	R/W	x0042	x00C2	x0142	x01C2	x0242	x02C2	x0342	x03C2

<b>SF1</b>	R/W	x0043	x00C3	x0143	x01C3	x0243	x02C3	x0343	x03C3
<b>LN1</b>	R/W	x0044	x00C4	x0144	x01C4	x0244	x02C4	x0344	x03C4
<b>RT2</b>	R/W	x0045	x00C5	x0145	x01C5	x0245	x02C5	x0345	x03C5
<b>SP2</b>	R/W	x0046	x00C6	x0146	x01C6	x0246	x02C6	x0346	x03C6
<b>ST2</b>	R/W	x0047	x00C7	x0147	x01C7	x0247	x02C7	x0347	x03C7
<b>SF2</b>	R/W	x0048	x00C8	x0148	x01C8	x0248	x02C8	x0348	x03C8
<b>LN2</b>	R/W	x0049	x00C9	x0149	x01C9	x0249	x02C9	x0349	x03C9
<b>RT3</b>	R/W	x004A	x00CA	x014A	x01CA	x024A	x02CA	x034A	x03CA
<b>SP3</b>	R/W	x004B	x00CB	x014B	x01CB	x024B	x02CB	x034B	x03CB
<b>ST3</b>	R/W	x004C	x00CC	x014C	x01CC	x024C	x02CC	x034C	x03CC
<b>SF3</b>	R/W	x004D	x00CD	x014D	x01CD	x024D	x02CD	x034D	x03CD
<b>LN3</b>	R/W	x004E	x00CE	x014E	x01CE	x024E	x02CE	x034E	x03CE
<b>RT4</b>	R/W	x004F	x00CF	x014F	x01CF	x024F	x02CF	x034F	x03CF
<b>SP4</b>	R/W	x0050	x00D0	x0150	x01D0	x0250	x02D0	x0350	x03D0
<b>ST4</b>	R/W	x0051	x00D1	x0151	x01D1	x0251	x02D1	x0351	x03D1
<b>SF4</b>	R/W	x0052	x00D2	x0152	x01D2	x0252	x02D2	x0352	x03D2
<b>LN4</b>	R/W	x0053	x00D3	x0153	x01D3	x0253	x02D3	x0353	x03D3
<b>RT5</b>	R/W	x0054	x00D4	x0154	x01D4	x0254	x02D4	x0354	x03D4
<b>SP5</b>	R/W	x0055	x00D5	x0155	x01D5	x0255	x02D5	x0355	x03D5
<b>ST5</b>	R/W	x0056	x00D6	x0156	x01D6	x0256	x02D6	x0356	x03D6
<b>SF5</b>	R/W	x0057	x00D7	x0157	x01D7	x0257	x02D7	x0357	x03D7
<b>LN5</b>	R/W	x0058	x00D8	x0158	x01D8	x0258	x02D8	x0358	x03D8
<b>RT6</b>	R/W	x0059	x00D9	x0159	x01D9	x0259	x02D9	x0359	x03D9
<b>SP6</b>	R/W	x005A	x00DA	x015A	x01DA	x025A	x02DA	x035A	x03DA
<b>ST6</b>	R/W	x005B	x00DB	x015B	x01DB	x025B	x02DB	x035B	x03DB
<b>SF6</b>	R/W	x005C	x00DC	x015C	x01DC	x025C	x02DC	x035C	x03DC
<b>LN6</b>	R/W	x005D	x00DD	x015D	x01DD	x025D	x02DD	x035D	x03DD
<b>RT7</b>	R/W	x005E	x00DE	x015E	x01DE	x025E	x02DE	x035E	x03DE
<b>SP7</b>	R/W	x005F	x00DF	x015F	x01DF	x025F	x02DF	x035F	x03DF
<b>ST7</b>	R/W	x0060	x00E0	x0160	x01E0	x0260	x02E0	x0360	x03E0
<b>SF7</b>	R/W	x0061	x00E1	x0161	x01E1	x0261	x02E1	x0361	x03E1
<b>LN7</b>	R/W	x0062	x00E2	x0162	x01E2	x0262	x02E2	x0362	x03E2
<b>RT8</b>	R/W	x0063	x00E3	x0163	x01E3	x0263	x02E3	x0363	x03E3
<b>SP8</b>	R/W	x0064	x00E4	x0164	x01E4	x0264	x02E4	x0364	x03E4
<b>ST8</b>	R/W	x0065	x00E5	x0165	x01E5	x0265	x02E5	x0365	x03E5
<b>SF8</b>	R/W	x0066	x00E6	x0166	x01E6	x0266	x02E6	x0366	x03E6
<b>LN8</b>	R/W	x0067	x00E7	x0167	x01E7	x0267	x02E7	x0367	x03E7
<b>CALIBRATION</b>									
<b>RTDL</b>	R/W	x0068	x00E8	x0168	x01E8	x0268	x02E8	x0368	x03E8
<b>RTDH</b>	R/W	x0069	x00E9	x0169	x01E9	x0269	x02E9	x0369	x03E9

<b>mAL</b>	R/W	x006A	x00EA	x016A	x01EA	x026A	x02EA	x036A	x03EA
<b>mAH</b>	R/W	x006B	x00EB	x016B	x01EB	x026B	x02EB	x036B	x03EB
<b>mVL</b>	R/W	x006C	x00EC	x016C	x01EC	x026C	x02EC	x036C	x03EC
<b>mVH</b>	R/W	x006D	x00ED	x016D	x01ED	x026D	x02ED	x036D	x03ED
<b>VL</b>	R/W	x006E	x00EE	x016E	x01EE	x026E	x02EE	x036E	x03EE
<b>VH</b>	R/W	x006F	x00EF	x016F	x01EF	x026F	x02EF	x036F	x03EF
<b>Troom</b>	R/W	x0070	x00F0	x0170	x01F0	x0270	x02F0	x0370	x03F0
<b>Revered</b>	N/A	x0071	x00F1	x0171	x01F1	x0271	x02F1	x0371	x03F1
<b>Revered</b>	N/A	x0072	x00F2	x0172	x01F2	x0272	x02F2	x0372	x03F2
<b>Revered</b>	N/A	x0073	x00F3	x0173	x01F3	x0273	x02F3	x0373	x03F3
<b>Revered</b>	N/A	x0074	x00F4	x0174	x01F4	x0274	x02F4	x0374	x03F4
<b>Revered</b>	N/A	x0075	x005	x0175	x01F5	x0275	x02F5	x0375	x03F5
<b>Revered</b>	N/A	x0076	x00F6	x0176	x01F6	x0276	x02F6	x0376	x03F6
<b>Revered</b>	N/A	x0077	x00F7	x0177	x01F7	x0277	x02F7	x0377	x03F7
<b>Revered</b>	N/A	x0078	x00F8	x0178	x01F8	x0278	x02F8	x0378	x03F8
<b>Revered</b>	N/A	x0079	x00F9	x0179	x01F9	x0279	x02F9	x0379	x03F9
<b>Revered</b>	N/A	x007A	x00FA	x017A	x01FA	x027A	x02FA	x037A	x03FA
<b>Revered</b>	N/A	x007B	x00FB	x017B	x01FB	x027B	x02FB	x037B	x03FB
<b>Revered</b>	N/A	x007C	x00FC	x017C	x01FC	x027C	x02FC	x037C	x03FC
<b>Revered</b>	N/A	x007D	x00FD	x017D	x01FD	x027D	x02FD	x037D	x03FD
<b>Revered</b>	N/A	x007E	x00FE	x017E	x01FE	x027E	x02FE	x037E	x03FE
<b>Revered</b>	N/A	x007F	x00FF	x017F	x01FF	x027F	x02FF	x037F	x03FF

This register map is showing channel 1 to channel 8 parameters. For those register address of channel 9 to channel 32, it can be calculated as followed:

$$\text{Register Address} = \text{Base Address} + (\text{Channel No.} - 1) * \text{x0080H}$$

Where the **Base Address** is the data register address of channel 1 parameter.

For example:

The base address of SV is **x0000H**

The SV register address of channel 6 (**x06H**) is

$$\text{x0280H} = \text{x0000H} + (\text{x06H} - 1) * \text{x0080H}$$

And the SV register address of channel 16 (**x10H**) is

$$\text{x0780H} = \text{x0000H} + (\text{x10H} - 1) * \text{x0080H}$$

#### Alarm Registers

### 4.3.2 Alarm Registers

Register		ALARM							
Parameter	Read/Write	#1	#2	#3	#4	#5	#6	#7	#8
ALPV	R/W	x1000	x1008	x1010	x1018	x1020	x1028	x1030	x1038
ALSP	R/W	x1001	x1009	x1011	x1019	x1021	x1029	x1031	x1039
ALHY	R/W	x1002	x100A	x1012	x101A	x1022	x102A	x1032	x103A
ALFU	R/W	x1003	x100B	x1013	x101B	x1023	x102B	x1033	x103B

ALMD	R/W	x1004	x100C	x1014	x101C	x1024	x102C	x1034	x103C
ALDT	R/W	x1005	x100D	x1015	x101D	x1025	x102D	x1035	x103D
Revered	N/A	x1006	x100E	x1016	x101E	x1026	x102E	x1036	x103E
Revered	N/A	x1007	x100F	x1017	x101F	x1027	x102F	x1037	x103F

Register		ALARM							
Parameter	Read/Write	#9	#10	#11	#12	#13	#14	#15	#16
ALPV	R/W	x1040	x1048	x1050	x1058	x1060	x1068	x1070	x1078
ALSP	R/W	x1041	x1049	x1051	x1059	x1061	x1069	x1071	x1079
ALHY	R/W	x1042	x104A	x1052	x105A	x1062	x106A	x1072	x107A
ALFU	R/W	x1043	x104B	x1053	x105B	x1063	x106B	x1073	x107B
ALMD	R/W	x1044	x104C	x1054	x105C	x1064	x106C	x1074	x107C
ALDT	R/W	x1045	x104D	x1055	x105D	x1065	x106D	x1075	x107D
Revered	N/A	x1046	x104E	x1056	x105E	x1066	x106E	x1076	x107E
Revered	N/A	x1047	x104F	x1057	x105F	x1067	x106F	x1077	x107F

Register		ALARM							
Parameter	Read/Write	#17	#18	#19	#20	#21	#22	#23	#24
ALPV	R/W	x1080	x1088	x1090	x1098	x10A0	x10A8	x10B0	x10B8
ALSP	R/W	x1081	x1089	x1091	x1099	x10A1	x10A9	x10B1	x10B9
ALHY	R/W	x1082	x108A	x1092	x109A	x10A2	x10AA	x10B2	x10BA
ALFU	R/W	x1083	x108B	x1093	x109B	x10A3	x10AB	x10B3	x10BB
ALMD	R/W	x1084	x108C	x1094	x109C	x10A4	x10AC	x10B4	x10BC
ALDT	R/W	x1085	x108D	x1095	x109D	x10A5	x10AD	x10B5	x10BD
Revered	N/A	x1086	x108E	x1096	x109E	x10A6	x10AE	x10B6	x10BE
Revered	N/A	x1087	x108F	x1097	x109F	x10A7	x10AF	x10B7	x10BF

Register		ALARM							
Parameter	Read/Write	#25	#26	#27	#28	#29	#30	#31	#32
ALPV	R/W	x10C0	x10C8	x10D0	x10D8	x10E0	x10E8	x10F0	x10F8
ALSP	R/W	x10C1	x10C9	x10D1	x10D9	x10E1	x10E9	x10F1	x10F9
ALHY	R/W	x10C2	x10CA	x10D2	x10DA	x10E2	x10EA	x10F2	x10FA
ALFU	R/W	x10C3	x10CB	x10D3	x10DB	x10E3	x10EB	x10F3	x10FB
ALMD	R/W	x10C4	x10CC	x10D4	x10DC	x10E4	x10EC	x10F4	x10FC
ALDT	R/W	x10C5	x10CD	x10D5	x10DD	x10E5	x10ED	x10F5	x10FD
Revered	N/A	x10C6	x10CE	x10D6	x10DE	x10E6	x10EE	x10F6	x10FE
Revered	N/A	x10C7	x10CF	x10D7	x10DF	x10E7	x10EF	x10F7	x10FF

		Bit															
Parameter	Register	15	14	13	12	11	10	9	8	7	6	5	4	3	2	1	0



ALFG1	x110E	A16	A15	A14	A13	A12	A11	A10	A9	A8	A7	A6	A5	A4	A3	A2	A1
ALFG2	x110F	A32	A31	A30	A29	A28	A27	A26	A25	A24	A23	A22	A21	A20	A19	A18	A17

### 4.3.3 AI Registers

Register		CHANNEL									
Parameter	Read / Write	#1	#2	#3	#4	#5	#6	#7	#8	#9	#10
AI	R	x1335	x1336	x1337	x1338	x1339	x133A	x133B	x133C	x133D	x133E
CT	R	x133F	x1340	x1341	x1342	x1343	x1344	x1345	x1346	x1347	x1348

### 4.3.4 DO and Alarm status Registers

DO 1 / ALFG 1		Bit															
Register	Read / Write	15	14	13	12	11	10	9	8	7	6	5	4	3	2	1	0
X110E	R / W	A16	A15	A14	A13	A12	A11	A10	A9	A8	A7	A6	A5	A4	A3	A2	A1

DO 2 / ALFG 2		Bit															
Register	Read / Write	15	14	13	12	11	10	9	8	7	6	5	4	3	2	1	0
x110F	R / W	A32	A31	A30	A29	A28	A27	A26	A25	A24	A23	A22	A21	A20	A19	A18	A17

### 4.3.5 DI Registers

DI		Bit															
Register	Read / Write	15	14	13	12	11	10	9	8	7	6	5	4	3	2	1	0
X1349	R	DI16	DI15	DI14	DI13	DI12	DI11	DI10	DI9	DI8	DI7	DI6	DI5	DI4	DI3	DI2	DI1

### 4.3.6 Other Registers (Reserved for Engineer Use Only)

Register		CHANNEL							
Parameter	Read/Write	#1	#2	#3	#4	#5	#6	#7	#8
PV	R	x1130	x1140	x1150	x1160	x1170	x1180	x1190	x11A0
OUT1	R	x1131	x1141	x1151	x1161	x1171	x1181	x1191	x11A1
OUT2	R	x1132	x1142	x1152	x1162	x1172	x1182	x1192	x11A2
FLAG	R	x1133	x1143	x1153	x1163	x1173	x1183	x1193	x11A3
WKNO	R	x1134	x1144	x1154	x1164	x1174	x1184	x1194	x11A4
TL	R	x1135	x1145	x1155	x1165	x1175	x1185	x1195	x11A5
TH	R	x1136	x1146	x1156	x1166	x1176	x1186	x1196	x11A6
PVO	R	x1137	x1147	x1157	x1167	x1177	x1187	x1197	x11A7
SVO	R	x1138	x1148	x1158	x1168	x1178	x1188	x1198	x11A8
PBAND	R	x1139	x1149	x1159	x1169	x1179	x1189	x1199	x11A9
ARW	R	x113A	x114A	x115A	x116A	x117A	x118A	x119A	x11AA
POUT	R	x113B	x114B	x115B	x116B	x117B	x118B	x119B	x11AB
IOUT	R	x113C	x114C	x115C	x116C	x117C	x118C	x119C	x11AC
DOUT	R	x113D	x114D	x115D	x116D	x117D	x118D	x119D	x11AD
CPOUT	R	x113E	x114E	x115E	x116E	x117E	x118E	x119E	x11AE

RESERVED	N/A	x113F	x114F	x115F	x116F	x117F	x118F	x119F	x11AF
----------	-----	-------	-------	-------	-------	-------	-------	-------	-------

This register map is showing channel 1 to channel 8 parameters. For those register address of channel 9 to channel 32, it can be calculated as followed:

$$\text{Register Address} = \text{Base Address} + (\text{Channel No.} - 1) * x0010H$$

Where the Base Address is the register address of channel 1 parameter.

For example:

The base address of PV is **x1130H**

The PV register address of channel 6 (**x06H**) is

$$x1180H = x1130H + (x06H - 1) * x0010H$$

And the PV register address of channel 16 (**x10H**) is

$$x1220H = x1130H + (x10H - 1) * x0010H$$